

Pneumatic Setup - ENFIELD *Electronic Proportional Valve Controller*

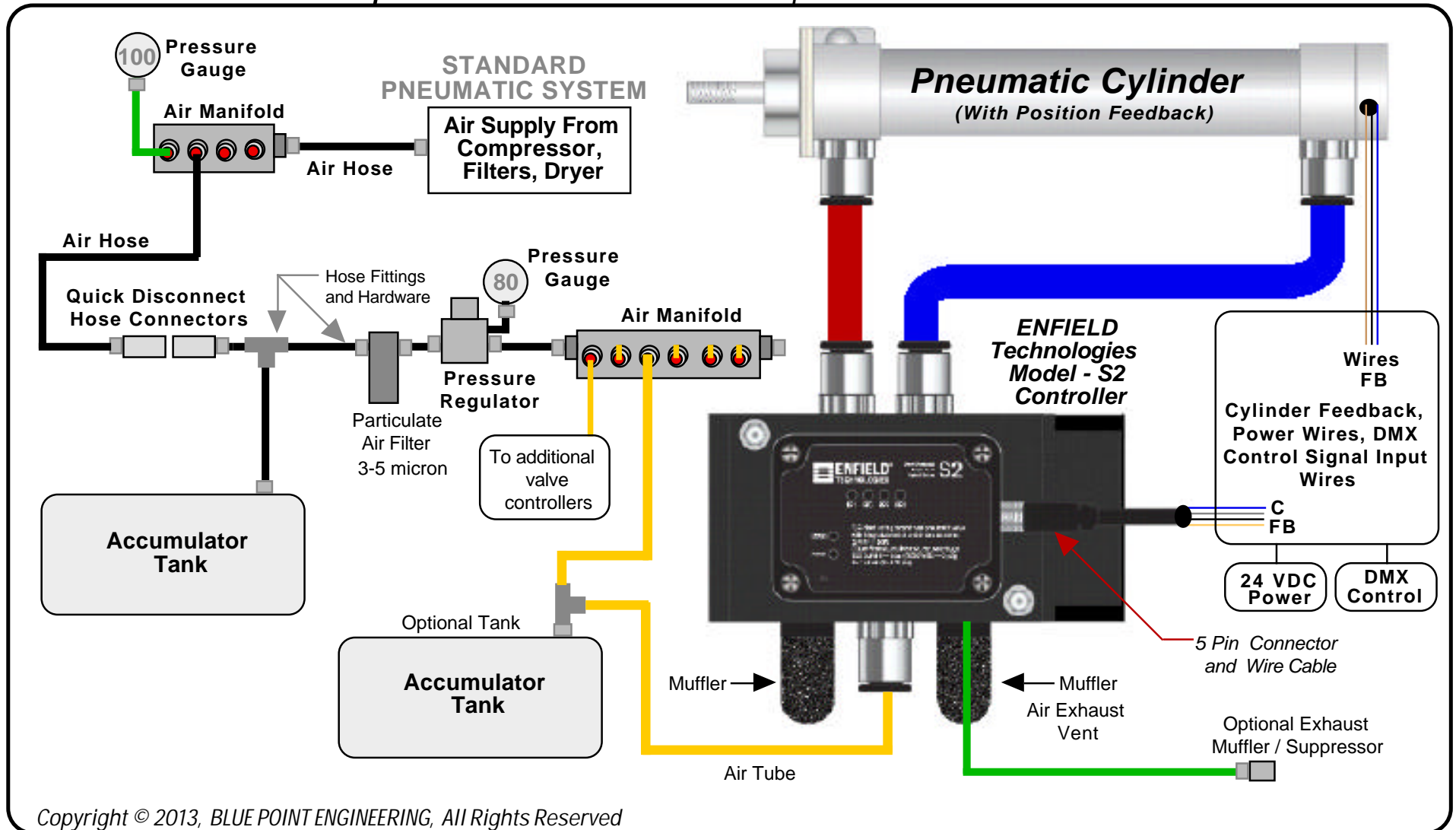

Servo-Pneumatic Proportional Control System - DMX

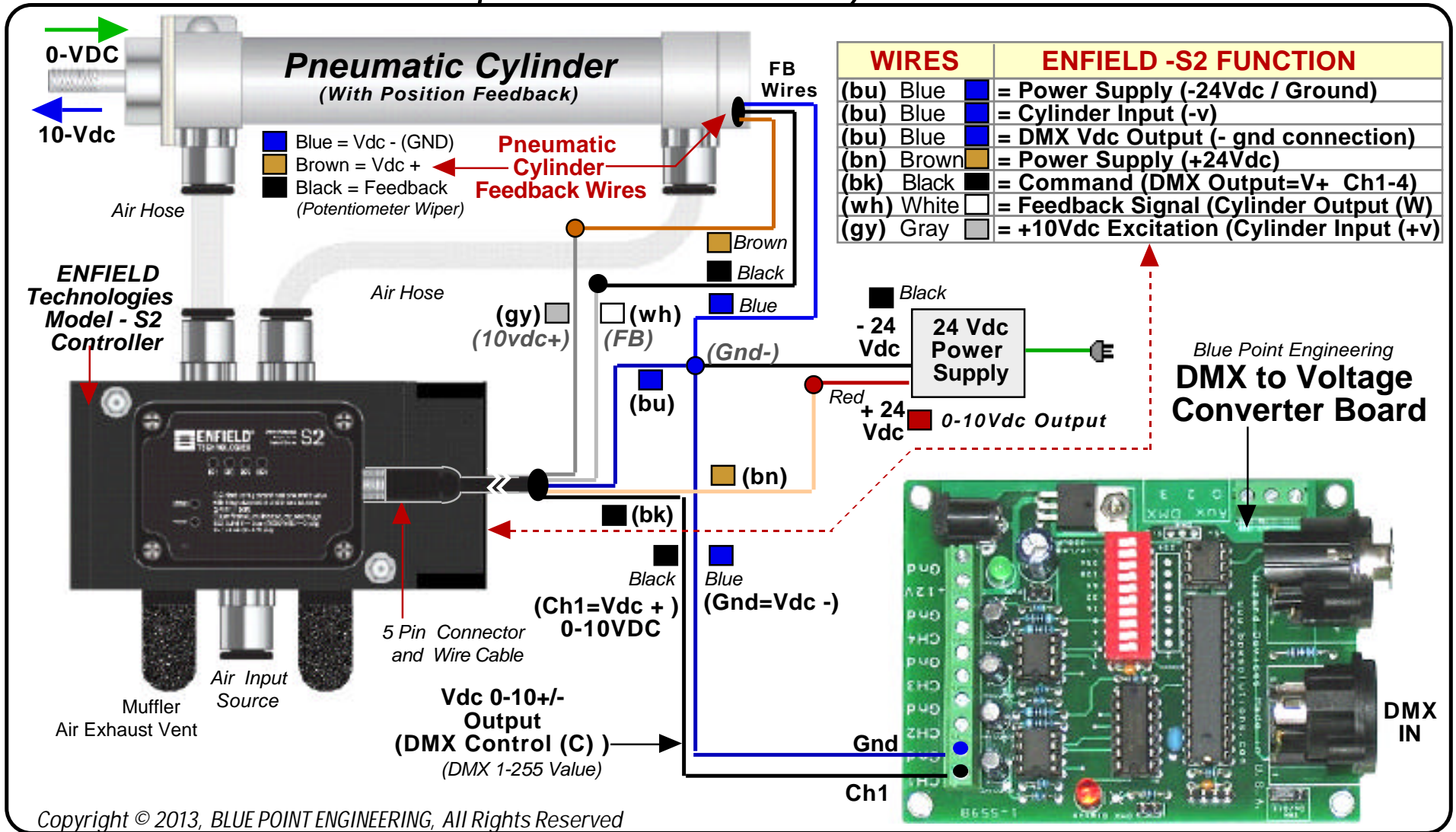

Copyright © 2013, BLUE POINT ENGINEERING, All Rights Reserved

Basic Pneumatic Setup - Animatronics

Pneumatic System

STANDARD PNEUMATIC SYSTEM REQUIREMENTS

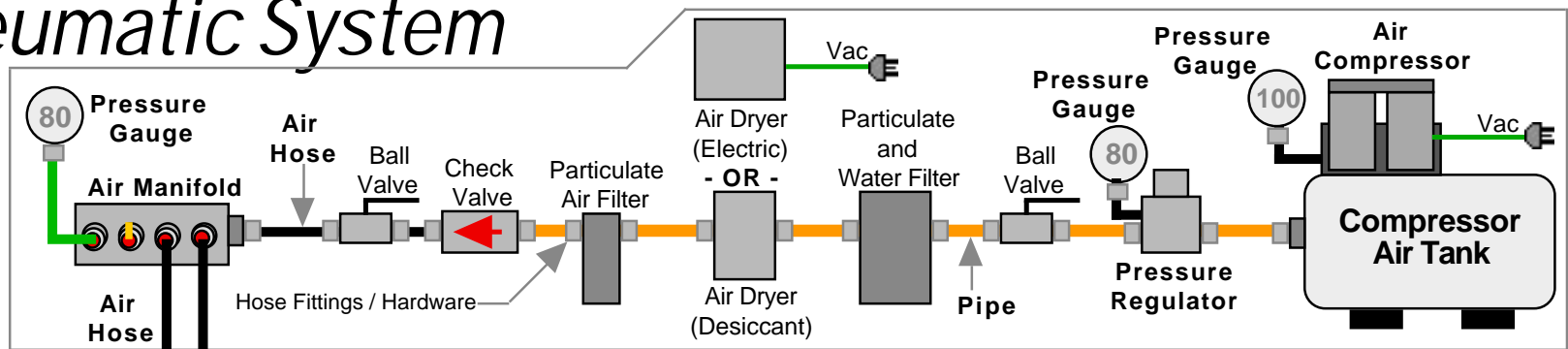

BASIC CONTROL

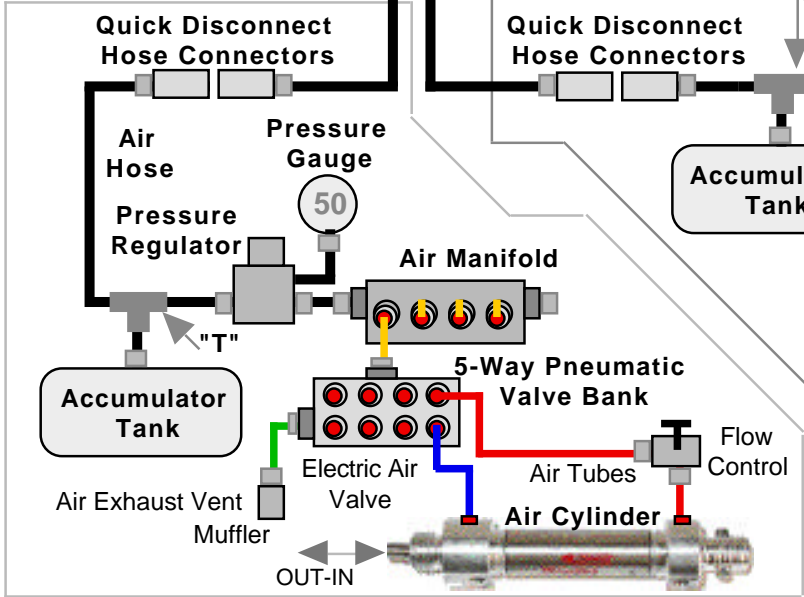

HYBRID CONTROL

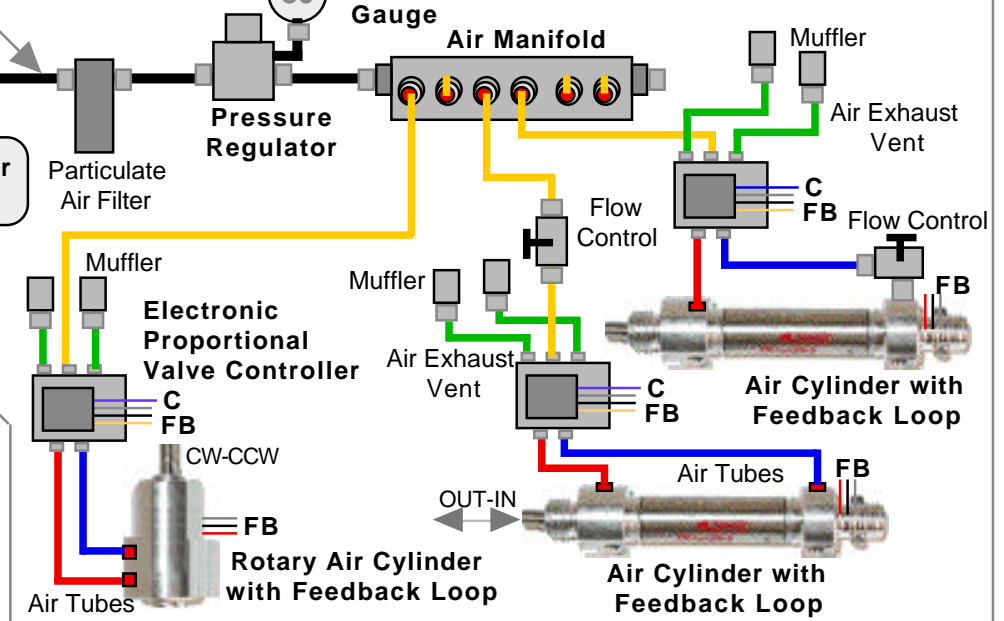

Copyright © 2013, BLUE POINT ENGINEERING, All Rights Reserved

Servo-Pneumatic Proportional Control System

