

Mini SSC IITM Serial Servo Controller

The Mini SSC II is an electronic module that controls eight pulse-proportional (“hobby”) servos according to instructions received serially at 2400 or 9600 baud. Two Mini SSC II units can share the same serial line to control a total of 16 servos. This addressability is expandable—you can order units programmed with other ranges of servo addresses so that a total of up to 32 Mini SSC IIs (controlling up to 255 servos) can share a single serial line.

Table of Contents

Connections and Configuration Jumpers	2
Configuring the Mini SSC II	2
Connecting the Mini SSC II	3
Initial Checkout	5
Programming for the Mini SSC II	5
Multiple Mini SSCs	5
Theory of Operation	6
Program Examples	7

Disclaimer of Liability

Scott Edwards Electronics, Inc. is not responsible for any special, incidental, or consequential damages resulting from any breach of warranty, or under any legal theory, including lost profits, downtime, goodwill, damage to or replacement of equipment or property, and any costs or recovering, reprogramming, or reproducing of data associated with the use of the hardware or software described herein.

Warranty

Scott Edwards Electronics, Inc. warrants this product against defects in materials and workmanship for a period of 90 days. If you discover a defect, we will, at our option, repair, replace, or refund the purchase price. Return the product with a description of the problem. We will return your product or its replacement via standard shipping. Expedited shipping is available at the customer’s expense.

- Note: Physically abusing the module, or attempting to repair or modify it, voids this warranty.

Trademarks and Copyrights

Mini SSCTM is a trademark of Scott Edwards Electronics, Inc.; BASIC Stamp[®] is a registered trademark of Parallax Inc. All trademarked names referenced herein are the property of their respective holders. This manual in its entirety is copyright Scott Edwards Electronics, Inc., 1999.

Connections and Configuration Jumpers

Figure 1 shows the layout of the Mini SSC II circuit board with the locations of connectors and configuration jumpers.

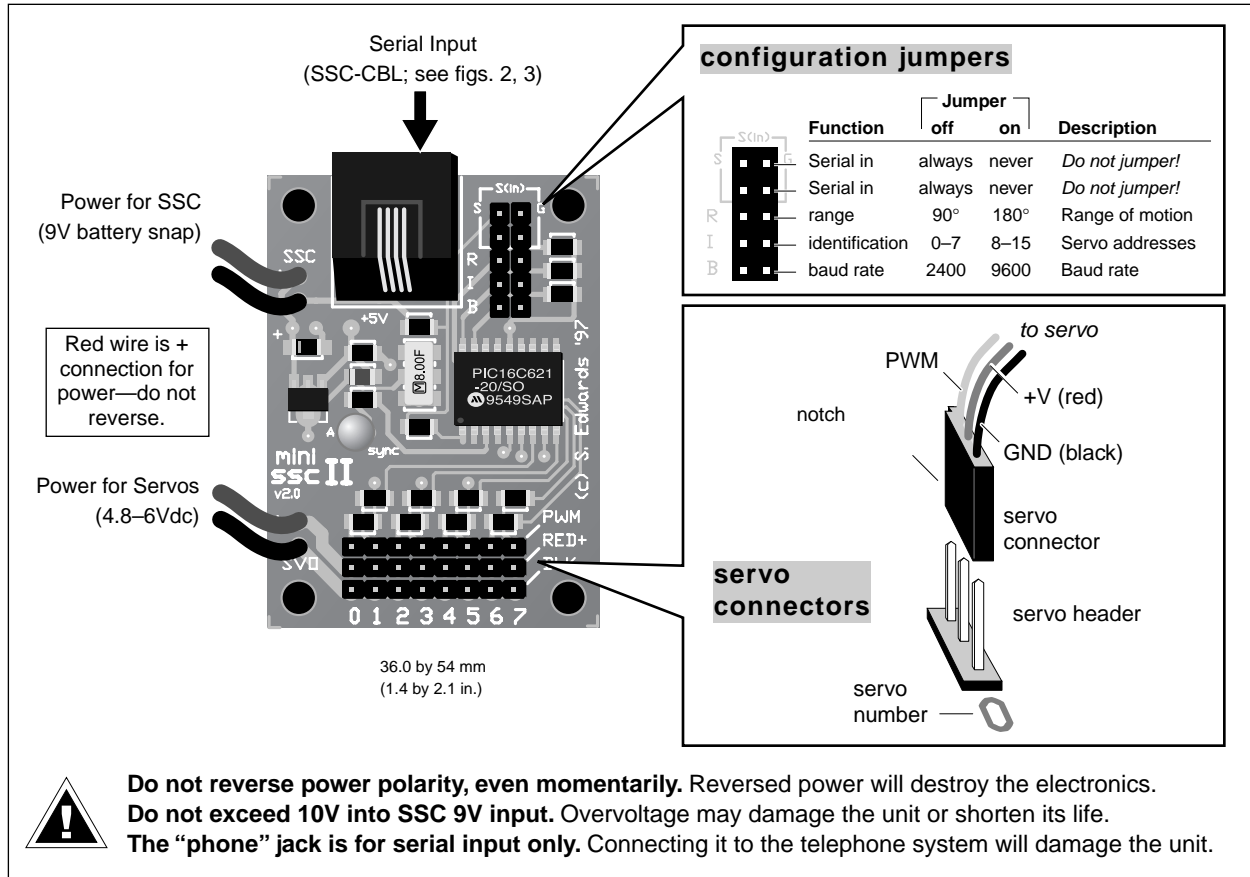

Figure 1. Layout of the Mini SSC II circuit board.

Configuring the Mini SSC II

The Mini SSC II's default configuration (all jumpers removed) is:

2400 baud • servos 0 through 7 • range of motion = 90°

To change a setting, install a jumper block across the appropriate pair of header posts as shown in the drawing at right. Changes take effect the next time the SSC is powered

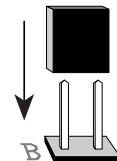

Here are more details on the configuration options:

(R)ange: With no jumper at R, the Mini SSC II controls servos over a 90° range of motion. Servos' positions are expressed in units from 0 to 254, so each unit corresponds to a 0.36° change in the servo's position. With a jumper at R, the Mini SSC II controls servos over as much as 180°, with each unit corresponding to a 0.72° change in position.

Configuring the Mini SSC II (continued)

Note Regarding Range: Some servos cannot move through a 180° range. They may stall when positions less than 50 or greater than 200 are used with the Mini SSC II in 180° mode. Always check out unfamiliar servos before using them with the Mini SSC II in 180° mode. Move the servo a few units at a time toward the end of travel and see whether it stalls. If it does, either use the servo only in 90° mode, or restrict position values to the safe range.

Please understand that servos are designed for 90° motion. The 180° mode exploits additional range that is meant as allowance for mechanical and electrical tolerances. In other words, it cheats a little to allow you to get the most from a given servo. There's nothing wrong with a servo that won't do 180°.

(I)dentification: With no jumper at I, servo addresses match the numbers printed next to the servo headers—0 through 7. With a jumper at I, the Mini SSC adds 8 to these addresses, so that the servo connected to "0" is addressed as 8, "1" as 9 ... and "7" as 15. This allows you to connect two Mini SSC IIs to the same serial port and address each of the servos individually. See *Multiple Mini SSCs* for information on controlling more Mini SSC IIs from a single serial port.

(B)aud: With no jumper at B, the Mini SSC II receives serial data at 2400 baud; with B jumpered the baud rate is 9600. In either case, the data should be sent as 8 data bits, no parity, 1 (or more) stop bit(s); abbreviated N81. In addition, the data should be inverted—just the way it comes from a standard

Connecting the Mini SSC II

Servos: The Mini SSC II connector accepts standard three-conductor servo plugs (e.g., Futaba-J connectors). See figure 1 for the correct way to attach these connectors.

Servo Power: Connect power for the servos (4.8 to 6Vdc) to the red (+) and black (–) wires marked SVO on the Mini SSC II board. Do not reverse + and –, even momentarily. This will damage the servos. For a power source, use a four-pack of alkaline C or D cells. For an ac power supply, use a regulated linear (not switching) supply rated for 5Vdc at 1A (or more). For more specific power-supply recommendations, see www.seetron.com/ssc_faq.htm.

Mini SSC II Power: Connect a 9V battery to the battery snap. If you want to use another power source, cut off the snap and connect 7 to 15Vdc to the wires, + to red and – to black. Do not reverse + and –, even momentarily. This can damage the electronics. The SSC power input is protected against accidental 9V battery reversal, but higher input voltages can defeat this protection.

Serial Input: The Mini SSC II requires only two connections to a computer—serial data and signal ground. There are two places to make these connections; a modular 'phone' jack and two pairs of pins marked S(in) on the configuration header. It doesn't matter which you use—pick the connection that is most convenient.

With single-board computers like the BASIC Stamp® you will probably use the header pins. Connect the Stamp I/O pin that your program will use for serial output to S on the Mini SSC II. This will be one of pins 0–7 on the Stamp I, or pins P0–P7 on the BS2. (Don't use BS2 pin Sout; it's for communicating with your PC during programming.) In either case, connect Stamp Ground (Vss) to G.

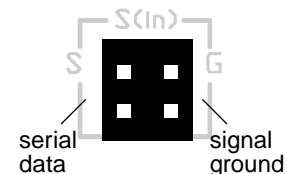

Note that there are two S pins and two G pins. These make a convenient tie point for connecting multiple Mini SSC IIs to the same serial input. See *Multiple Mini SSCs*.

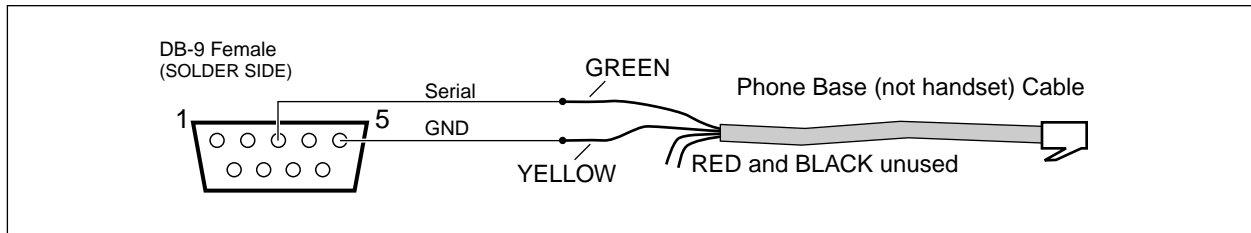

Figure 2. Wiring DB9 serial connector to a modular cable for use with SSC.

Connecting the Mini SSC II (continued)

Figure 2 above shows how to wire an SSC cable for use with the DB9 connector found on PCs and other computers. If you prefer not to make your own cable, a ready-made one is available from Scott Edwards Electronics Inc. as part number SSC-CBL (online, www.seetron.com). You may purchase the components used in this cable from James Electronics (www.jameco.com or 1-800-831-4242). Figure 3 shows how the cable is assembled:

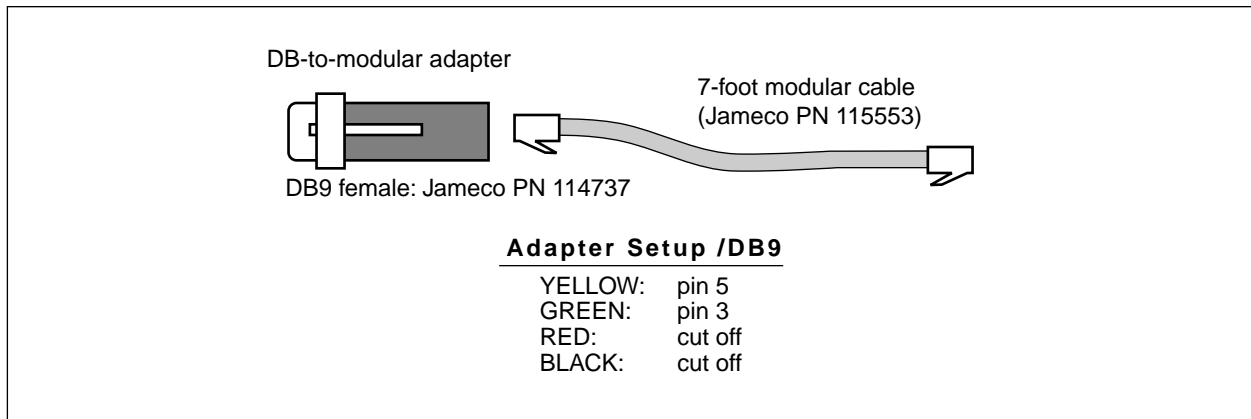

Figure 3. Solderless SSC cable (equivalent to SSC-CBL).

The DB9-to-modular adapter comes disassembled. To assemble it, push the pin sockets into the numbered holes in the housing as indicated in the drawing above. Snap the adapter housing together and plug in the modular cable. Note that you can use most any modular cable intended for connecting a phone to the wall jack. The only requirement is that the cable be a four-wire type (with yellow, green, red, and black wires all connected). Two-wire cables that come with cheap telephones have only the red and black wires, and won't work. You can check by looking through the transparent phone-plug body—if you see four wires, it's OK.

NEVER connect the Mini SSC II to the phone line!

25-pin Serial Ports: These are almost extinct, but if your computer has one, just use a commercial DB25-to-DB9 adapter and one of the cables shown above.

Initial Checkout

When the Mini SSC II is first powered up, it will turn on the Sync LED and move all servos to the centered position (see Theory of Operation). Once you have connected servos, servo power, and Mini SSC power, the servos will immediately swing to center. If they are already centered, they may not move much, but you can confirm proper operation by trying to move a servo with your fingers (gently). The servo will resist your efforts to move it. If it doesn't, recheck servo and power connections.

The Green Light: At powerup, the green Sync LED indicates not only that the Mini SSC II is receiving power, but also that its microcontroller is working properly (passed startup initialization). If the green light comes on, but servos don't appear to be responding correctly, the problem is most likely with servo connections, servo power, or serial hookup, not with the Mini SSC II.

Serial Checkout: To verify proper serial hookup, run one of the demonstration programs, a commercial Mini SSC II software package (see www.seetron.com/ssc.htm for a list), or a serial-test program (such as Serial Sender, available free from www.seetron.com/dl.shtml). Make sure that the program's baud rate matches the Mini SSC II's setting, and that the I/O pin or comm port selected for serial output is the one the Mini SSC II is connected to.

Programming for the Mini SSC II

To command a servo to a new position requires sending three bytes at the appropriate serial rate (2400 or 9600 baud, depending on the setting of the B jumper; see Configuring the Mini SSC II). These bytes

Byte 1	Byte 2	Byte 3
[sync marker (255)]	[servo # (0-254)]	[position (0-254)]

These must be sent as individual byte values, not as text representations of numbers as you might type at a keyboard. The example programs at the back of this manual show how to convert numbers to byte values. In PBASIC, you just omit any text-formatting functions (# for the BS1; DEC, HEX, ?, etc. for the BS2). In other BASICs, use the CHR\$ function to convert numbers to bytes.

The Sync LED on the Mini SSC II board can help you debug your serial routines. It lights steadily when power is first applied to the board and stays on until the first complete three-byte instruction is received. Thereafter, the LED lights only after a valid sync marker and servo address are received. It stays on until a position byte is received, then turns off. If your program is sending lots of data to the Mini SSC II, the LED will appear to light steadily, but will actually be blinking very rapidly.

Windows 95/98/NT programming: A 32-bit Windows DLL is available free from our web site at www.seetron.com/ssc_an1.htm. Documentation includes a complete description of the DLL, plus program examples for Microsoft Visual BASIC 6 and Borland Delphi 5. The DLL may be used with any Windows programming environment that supports DLLs.

Multiple Mini SSCs

To control two Mini SSC IIs, connect them in parallel to the same serial line; see wiring suggestions on the next page. Set both units for the same baud rate. Install a jumper at the I configuration header of one; leave this header open on the other. Address the servos as follows:

Jumper at I?	Servo Numbers
no	0-7
yes	8-15

Multiple Mini SSCs (continued)

Wiring suggestions for multiple Mini SSC IIs: Once you have one Mini SSC II connected to a computer, connecting additional units is easy. Just wire the S and G pins of the first Mini SSC II to the S and G pins of the second. Do the same for the second and third, third and fourth, and so on. Since there are two S pins and two G pins on each Mini SSC II, this is simple.

To make these connections without soldering, use Connectamundos jumper wires (CNX-010) from Scott Edwards Electronics, Inc. These have sockets that fit the pins on the Mini SSC II board (or any 0.025"

More than 16 servos: With a jumper installed at I, the Mini SSC II adds 8 to the servo addresses, so that servo 0's address is 8, servo 1 is 9...and servo 7 is 15. If you need to control more than 16 servos, you may special-order Mini SSC IIs with higher address ranges from the manufacturer. For example, your third and fourth Mini SSC IIs would have a base address (the address corresponding to servo 0 with no I jumper) of 16. Part numbers for these special Mini SSC IIs is SSC-ASD2-n, where n is the base servo number. The table below lists the first five part numbers and the range of servo numbers they cover.

Part Number	Servo #s (no jumper at I)	Servo #s (jumper at I)
SSC-ASD2 (standard)	0—7	8—15
SSC-ASD2-16	16—23	24—31
SSC-ASD2-32	32—39	40—47
SSC-ASD2-48	48—55	56—63
SSC-ASD2-64	64—71	72—79

Theory of Operation

Pulse-proportional servos are designed for use in radio-controlled (R/C) cars, boats and planes. They provide precise control for steering, throttle, rudder, etc. using a signal that is easy to transmit and receive. The signal consists of pulses ranging from 1 to 2 milliseconds long, repeated 60 times a second. The servo positions its output shaft in proportion to the width of the pulse, as shown in Figure 5.

In radio-control applications, a servo needs no more than a 90° range of motion, since it is usually driving a crank mechanism that can't move more than 90°. So when you send pulses within the manufacturer-specified range of 1 to 2 ms, you get a 90° range of motion. With no jumper at the (R)ange header, a position value of 0 corresponds to 1-ms pulses; 254 to 2.016 ms. A 1-unit change in position value produces a 4-microsecond change in pulse width. Positioning resolution is 0.36°/unit (90°/250).

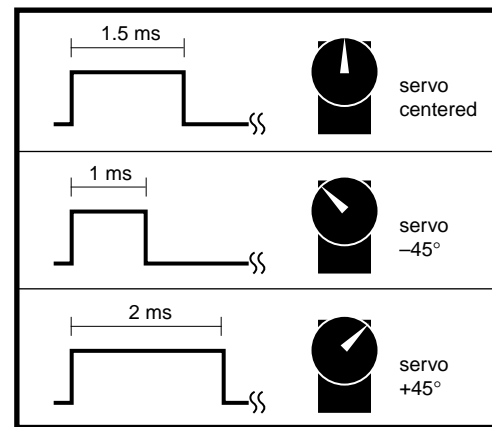

Figure 5. Servos are controlled by 1- to 2-ms pulses repeating at 60Hz.

Most servos have more than 90° of mechanical range, though, in order to allow adjustment for component variations, mounting position, etc. The Mini SSC II lets you use this extra range. With a jumper at (R)ange, a position value of 0 corresponds to 0.5-ms pulse; 254 to 2.53 ms. A 1-unit change in position value produces a 8-microsecond change in pulse width. Positioning resolution is 0.72°/unit (180°/250).

Program Examples

```
' Listing 1. BASIC Stamp I Program Demonstrating the Mini SSC
' Program: SCAN.BAS (BS1 servo control demo)
' This program demonstrates servo control using the MiniSSC.
' It commands servo 0 slowly and smoothly through its full
' range of travel. To run this program, leave all configuration
' jumpers off the Mini SSC board. Connect:
'
'      BS1      Mini SSC      Purpose
'      -----      -
'      pin0      S(in) pin S      Serial signal
'      Vss       S(in) pin G      Ground
' Plug a servo into Mini SSC output 0 and connect power as described
' in the manual. Run this program. The servo will slowly scan back
' and forth. Change for/next step values to change servo movement.
SYMBOL svo = 0      ' Use servo 0.
SYMBOL sync = 255   ' Mini SSC sync byte.
SYMBOL pos = b2     ' Byte variable b2 holds position value.
again:
  for pos = 0 to 254 step 1      ' Rotate clockwise in 1-unit steps.
    serout 0,n2400,(sync,svo,pos) ' Command the Mini SSC.
  next pos      ' Next position.
  for pos = 254 to 0 step -1     ' Rotate counter-clock, 1-unit steps.
    serout 0,n2400,(sync,svo,pos) ' Command the mini SSC.
  next pos      ' Next position.
goto again      ' Do it again.
```

```
' Listing 2. BASIC Stamp II Program Demonstrating the Mini SSC
' Program: SCAN.BS2 (BS2 servo control demo)
' This program demonstrates servo control using the MiniSSC.
' It commands servo 0 slowly and smoothly through its full
' range of travel. To run this program, install a jumper at
' B on the Mini SSC board; leave all other jumpers off.
' Connect:
'
'      BS2      Mini SSC      Purpose
'      -----      -
'      P0       S(in) pin S      Serial signal
'      Vss       S(in) pin G      Ground
' Plug a servo into Mini SSC output 0 and connect power as described
' in the manual. Run this program. The servo will slowly scan back
' and forth. Try changing the step values in the for/next loops
' to see the effect on servo movement.
svo con 0      ' Use servo 0.
sync con 255   ' Mini SSC sync byte.
pos var byte   ' Byte variable holds position value.
n96n con $4054 ' Baudmode: 9600 baud (BS2-SX, change to $40F0).
n24n con $418D ' Baudmode: 2400-baud (BS2-SX, change to $43FD).
```

(more on next page)

' **BS2 program example, continued.**

```
again:
  for pos = 0 to 254 step 1      ' Rotate clockwise in 1-unit steps.
    serout 0,n96n,[sync,svo,pos] ' Command the mini SSC.
  next                          ' Next position.
  for pos = 254 to 0 step 1     ' Rotate counter-clock, 1-unit steps.
    serout 0,n96n,[sync,svo,pos] ' Command the mini SSC.
  next                          ' Next position.
goto again                      ' Do it again.
```

' **Listing 3. QBASIC Program for PCs Demonstrating the Mini SSC**

' Note: This program is written for QBASIC, an old, but still common
' MS-DOS programming language. For programming under Windows 95 or
' greater with Visual BASIC see www.seetron.com/ssc_an1.htm .

```
DEFINT A-Z
Sync.byte = 255
' The line below assumes that the B jumper is installed for
' 9600-baud operation.
OPEN "com1:9600,N,8,1,CD0,CS0,DS0,OP0" FOR OUTPUT AS #1
CLS
PRINT "          MINI SERIAL SERVO CONTROLLER"
PRINT : PRINT
PRINT "At the prompt, type the servo number (0 to 7), a comma,
PRINT "and a position value (0 to 254).\"
PRINT "Press <CNTL> - <Break> to end.\"
Again:
  LOCATE 8, 1
  PRINT "          \"
  LOCATE 8, 1
  INPUT "Servo,position>\", Servo, Position
' Perform some basic error trapping
  IF Servo > 7 THEN Servo = 7
  IF Servo < 0 THEN Servo = 0
  IF Position > 254 THEN Position = 254
  IF Position < 0 THEN Position = 0
  PRINT #1, CHR$(Sync.byte); CHR$(Servo); CHR$(Position);
GOTO Again
```
