

# Wireless Radio Control of Puppets

## Hardware Setup Overview

### Setup Overview

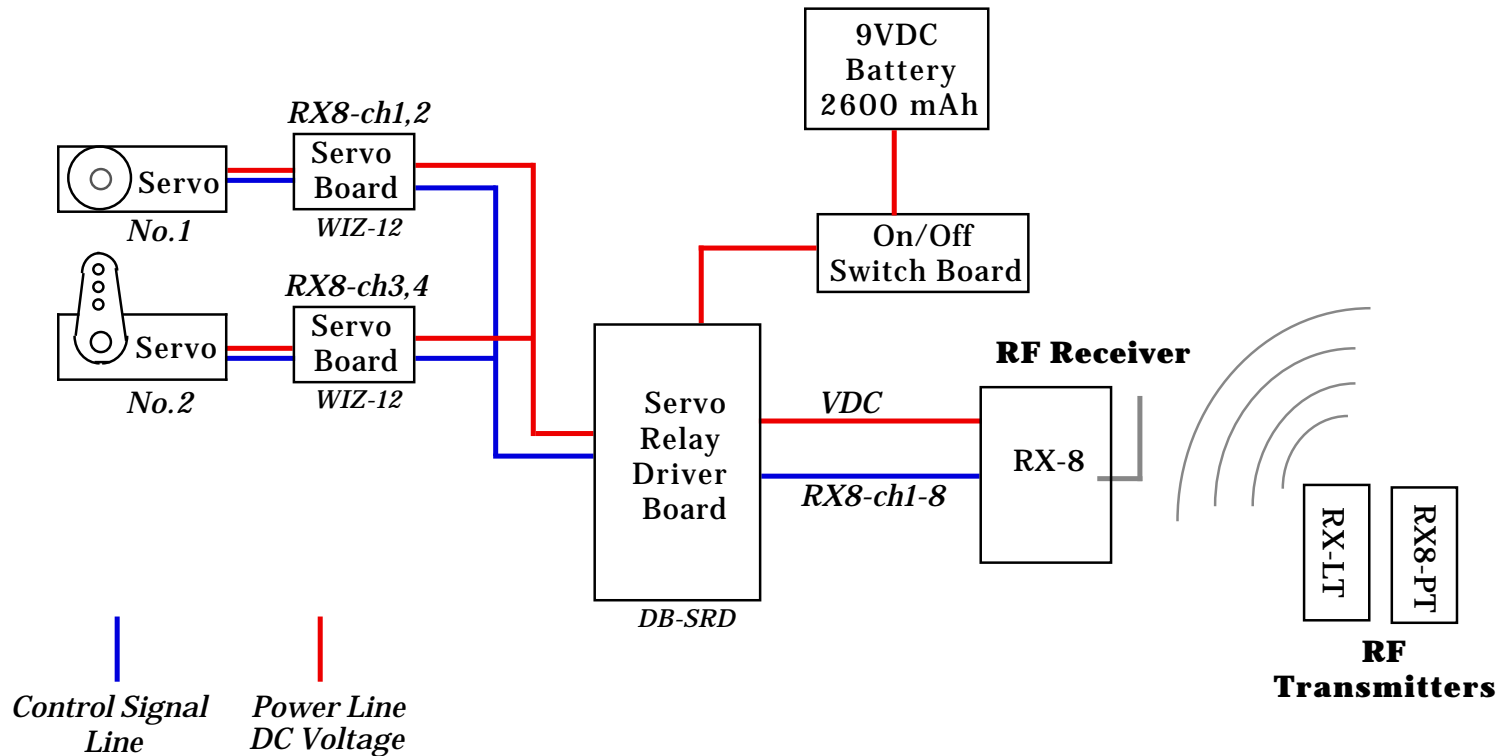

Copyright © 2011 Blue Point Engineering All Rights Reserved

For more information on these products or to place an order

Blue Point Engineering Inc.

[www.BPEsolutions.com](http://www.BPEsolutions.com)

Phone (303) 651-3794

# RX8 to SRD Board

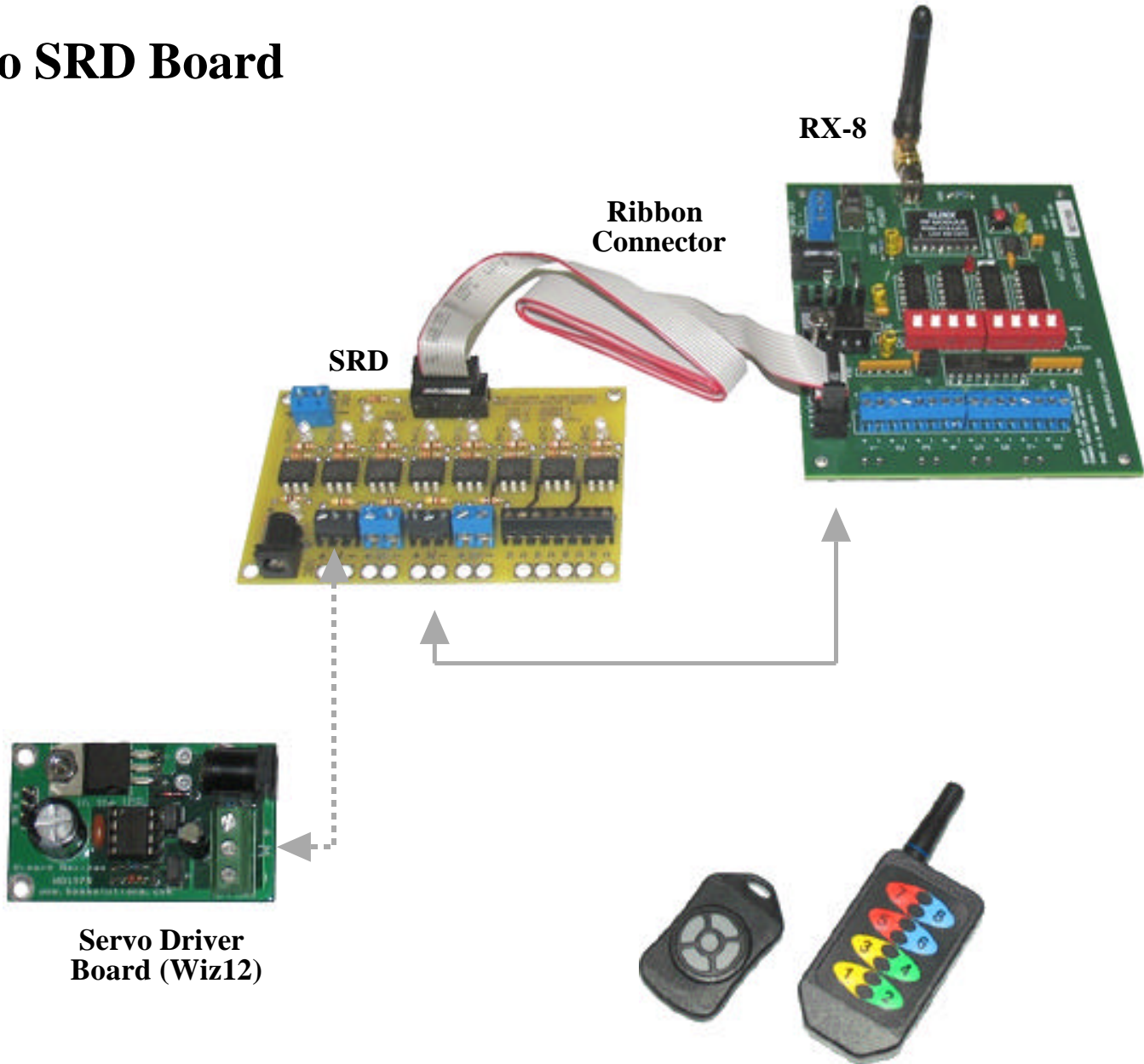

# SRD Board Overview

Servo / Relay Driver Board

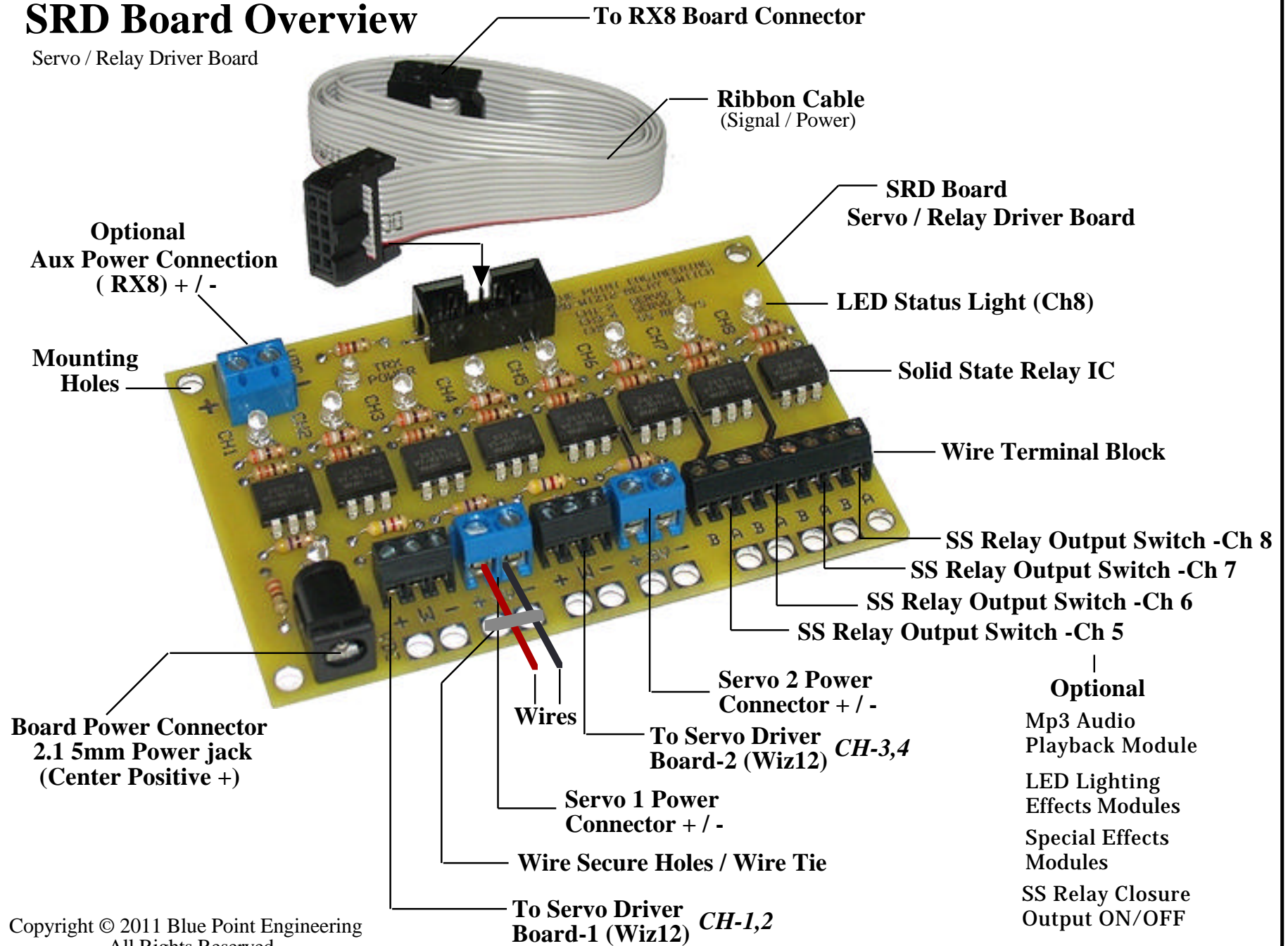



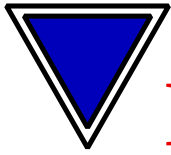

## RX-8 RF System RF Handheld Modules

### Set - Up / Changing Address

### Long Range Handheld Transmitter

The RF Long Range Handheld Transmitter allows the selection of one of 16,777,216 ( $2^{24}$ ) unique addresses. All Transmitters come ready to go with an address preset. To avoid conflict with other units or to create your own unique address or add additional RF Receiver boards, you will need to change the RF handheld Transmitter and RF Receiver board address.

#### RF Long Range Handheld Transmitter

Using a paper clip, press the CREATE button down on the RF handheld Transmitter through the hole in the back of the case. A LED will now light up indicating that the new address is being created. The address will be randomized for as long as the button is held down. Release the button and the new randomized address will be activated. The LED will begin flashing to indicate that the Control Permission Buttons access may now be set. Press the buttons 1-8 on the front of RF handheld transmitter. Press the CREATE button with the paper clip again to record you actions. A new button address and Control Permissions are now set in the RF handheld Transmitter. The RF Receiver board will now need to learn the address before it will accept any handheld button transmissions.

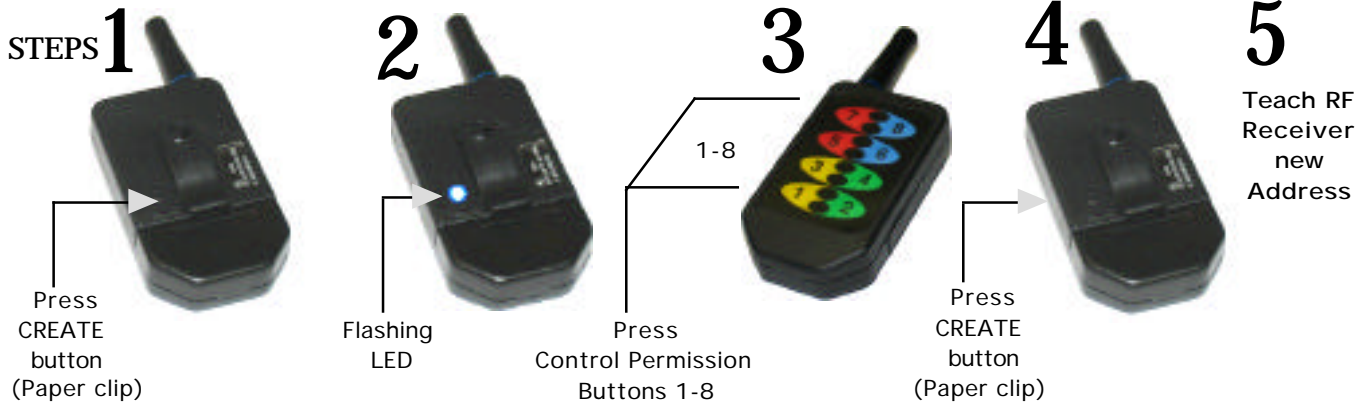

#### RF Receiver Board - 8 Channel

Press the LEARN button down momentarily on the RF Receiver board. The Yellow LED will begin flashing indicating that the Receiver board is ready to learn the new handheld Transmitter addresses. Press buttons 1-8 on the front of the RF handheld Transmitter. Press the LEARN button down momentarily on the RF Receiver board again to record the actions of the handheld Transmitter buttons. The RF Receiver board is now ready to recognize the handheld Transmitter buttons and turn on the corresponding output channels 1-8 when activated by the handheld Transmitter. Test the system by pressing a button on the RF handheld Transmitter; a corresponding output on the RF Receiver board should be activated 1-8 (LED- Green ON).

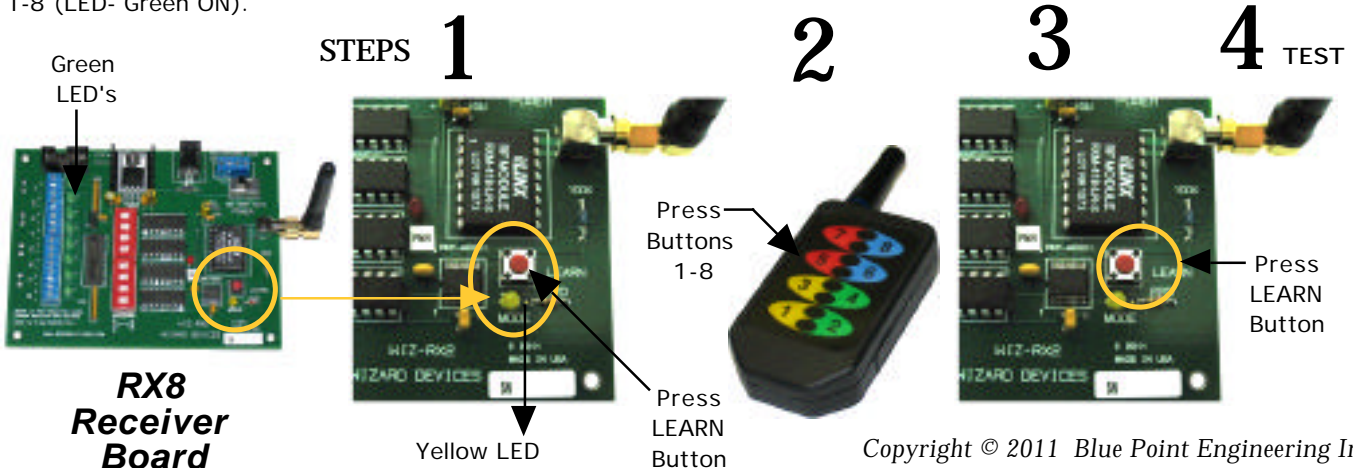

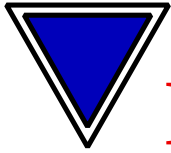

## RX-8 RF System RF Handheld Modules

### Set - Up / Battery - Transmission

#### BATTERY REPLACEMENT

The LR remote unit utilizes a standard CR2032 Lithium Button Cell . In normal use, it will provide 1 to 2 years of operation. To replace the battery, remove the access cover by pressing firmly down on the area and sliding it off. Once the unit is open, remove the battery by sliding it from beneath the holder. There may be the risk of explosion if the battery is replaced by the wrong type. Replace it with the same type of battery while observing the correct battery +/- polarity.

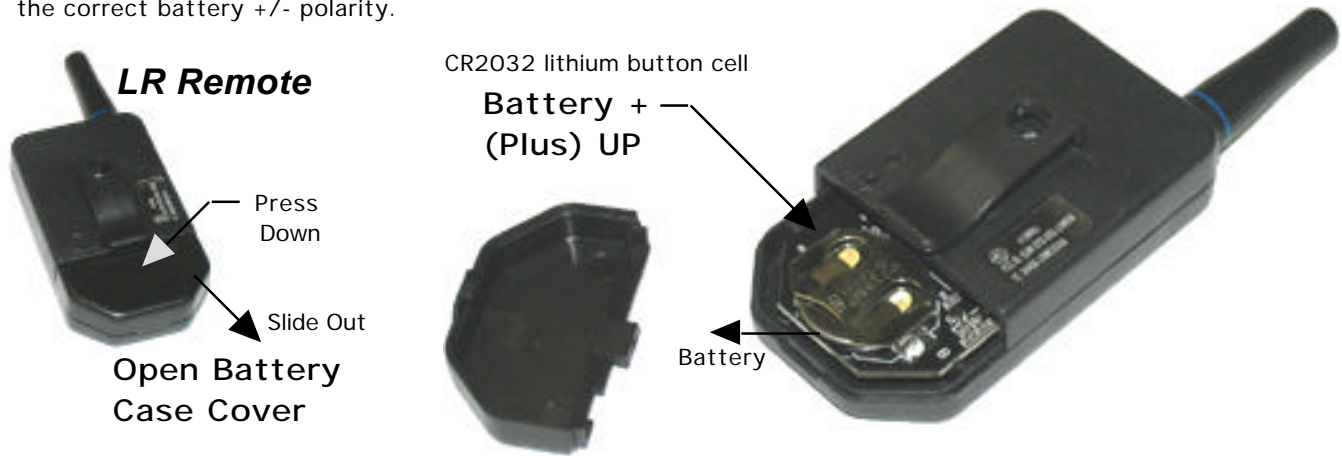

**CAUTION:** Observe battery polarity

#### RF Transmitter and Receiver CONSIDERATIONS

Only one Transmitter at a time can be activated within a reception area. While the Transmitted signal consists of encoded digital data, only one carrier of any particular frequency can occupy airspace at any given time. If two identical Transmitters are activated in the same area at the same time, then the signals will interfere with each other and the decoder will not see a valid transmission if the address is the same. **NOTE:** Two Receiver boards or more can be activated at the same time and share a common RF handheld Transmitter address or two Transmitters of different addressing and associated Receiver boards can be used in the same reception area with no interference issues usually.

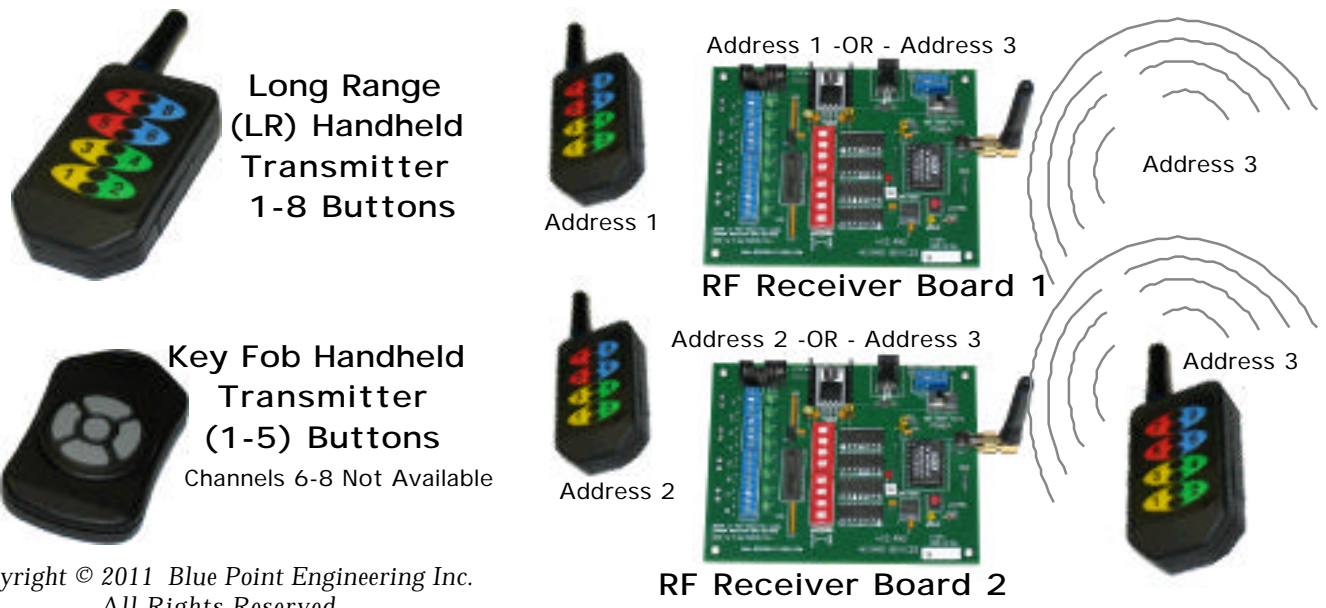

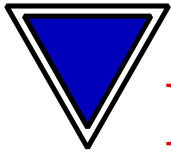

## RX-8 RF System RF Handheld Modules

### Set - Up / Changing Address

### Key Fob Handheld Transmitter

The RF Key Fob Handheld Transmitter allows the selection of one of 16,777,216 ( $2^{24}$ ) unique addresses. All transmitters come ready to go with an address preset. To avoid conflict with other units or to create your own unique address or add additional RF receiver boards, you will need to change the RF handheld Transmitter and RF receiver board address.

### RF Key Fob Handheld Transmitter

Using a paper clip, press the ADD button down on the RF handheld Transmitter through the hole in the back of the case. The address will be randomized for as long as the button is held down. Release the button and the new randomized address will be activated. Press the buttons 1-5 on the front of RF handheld Transmitter. Press the ADD button with the paper clip again to record you actions or wait 17 seconds for it to time out. A new button address and Control Permissions are now set in the RF handheld Transmitter. The RF Receiver board will now need to learn the address before it will accept any handheld Key Fob button transmissions 1-5.



### RF Receiver Board - 8 Channel

Press the LEARN button down momentarily on the RF Receiver board. The Yellow LED will begin flashing indicating that the Receiver board is ready to learn the new handheld Transmitter addresses. Press buttons 1-5 on the front of the RF handheld Transmitter. Press the LEARN button down momentarily on the RF Receiver board again to record the actions of the handheld Transmitter buttons. The RF Receiver board is now ready to recognize the handheld Transmitter buttons and turn on the corresponding output channels 1-5 when activated by the handheld Transmitter. Test the system by pressing a button on the RF handheld Transmitter; a corresponding output on the RF Receiver board should be activated 1-5 (LED- Green ON). NOTE: LED's 6-8 and Channels 6-8 Not used with Key Fob Transmitter

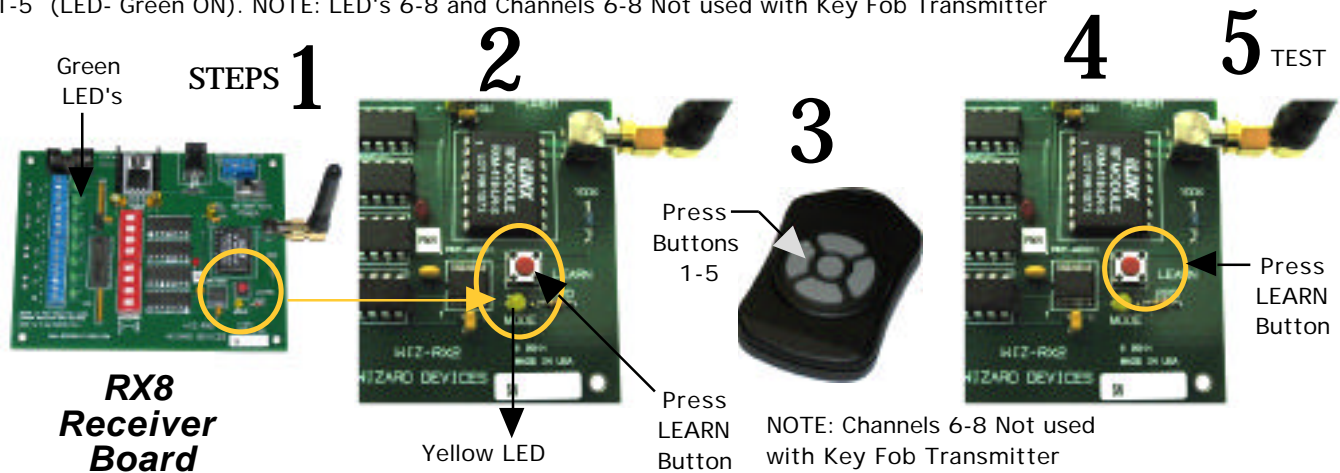

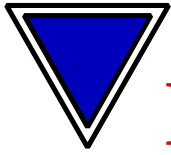

## RX-8 RF System *Multiple Receiver Boards*

### Set - Up / Changing - Set Address

#### RF Long Range Handheld Transmitter

Using a paper clip, press the CREATE button down on the RF handheld Transmitter through the hole in the back of the case. A LED will now light up indicating that the new address is being created. The address will be randomized for as long as the button is held down. Release the button and the new randomized address will be activated. The LED will begin flashing to indicate that the Control Permission Buttons access may now be set. Press the buttons 1-8 on the front of RF handheld transmitter. Press the CREATE button with the paper clip again to record your actions. A new button address and Control Permissions are now set in the RF handheld Transmitter. The RF Receiver board will now need to learn the address before it will accept any handheld button transmissions.



#### RF Receiver Board No.1 - 8 Channel

Press the LEARN button down momentarily on the RF Receiver board No.1. The MODE Yellow LED will begin flashing indicating that the Receiver board No.1 is ready to learn the new handheld Transmitter addresses. Press buttons 1-8 on the front of the RF handheld Transmitter. Press the LEARN button down momentarily on the RF Receiver board No.1 again to record the actions of the handheld Transmitter buttons. The RF Receiver board No.1 is now ready to recognize the handheld Transmitter buttons and turn on the corresponding output channels 1-8 when activated by the handheld Transmitter. Test the system by pressing a button on the RF handheld Transmitter; a corresponding output on the RF Receiver board No.1 should be activated 1-8 (LED- Green ON).

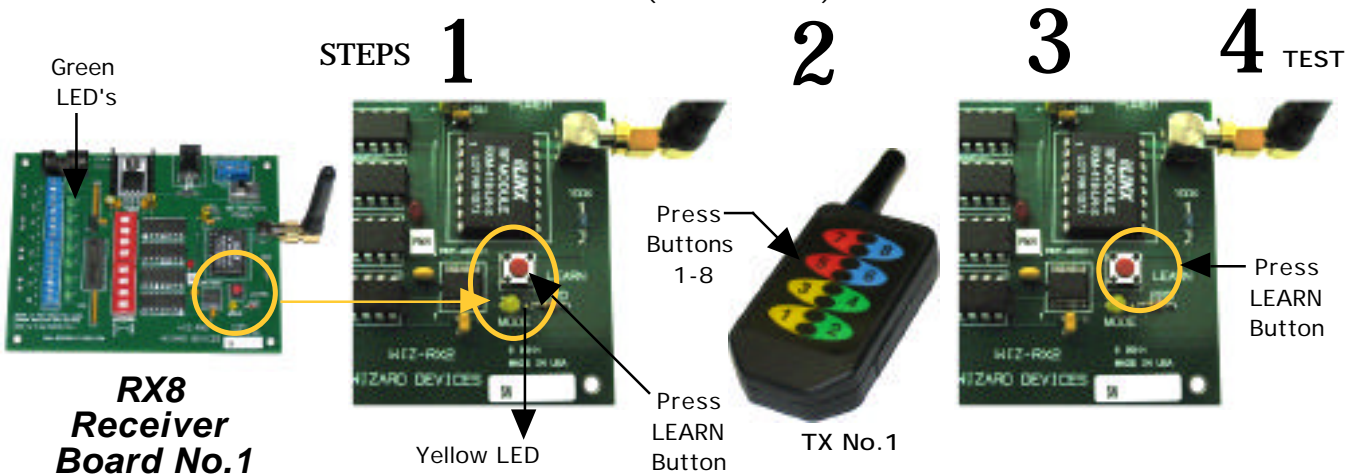



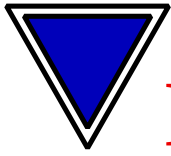

## RX-8 RF System Multiple Receiver Boards

### Set - Up / Changing - Set Address

#### RF Receiver Board No.2 - 8 Channel

Press the LEARN button down momentarily on the RF Receiver board No.2. The MODE Yellow LED will begin flashing indicating that the Receiver board No.2 is ready to learn the new handheld Transmitter addresses you just used on Receiver No.1 board. Press buttons 1-8 on the front of the RF handheld Transmitter. Press the LEARN button down momentarily on the RF Receiver board No.2 again to record the actions of the handheld Transmitter buttons. The RF Receiver board No.2 is now ready to recognize the handheld Transmitter buttons and turn on the corresponding output channels 1-8 when activated by the handheld Transmitter. Test the system by pressing a button on the RF handheld Transmitter; a corresponding output on the RF Receiver board No.2 should be activated 1-8 (LED- Green ON).

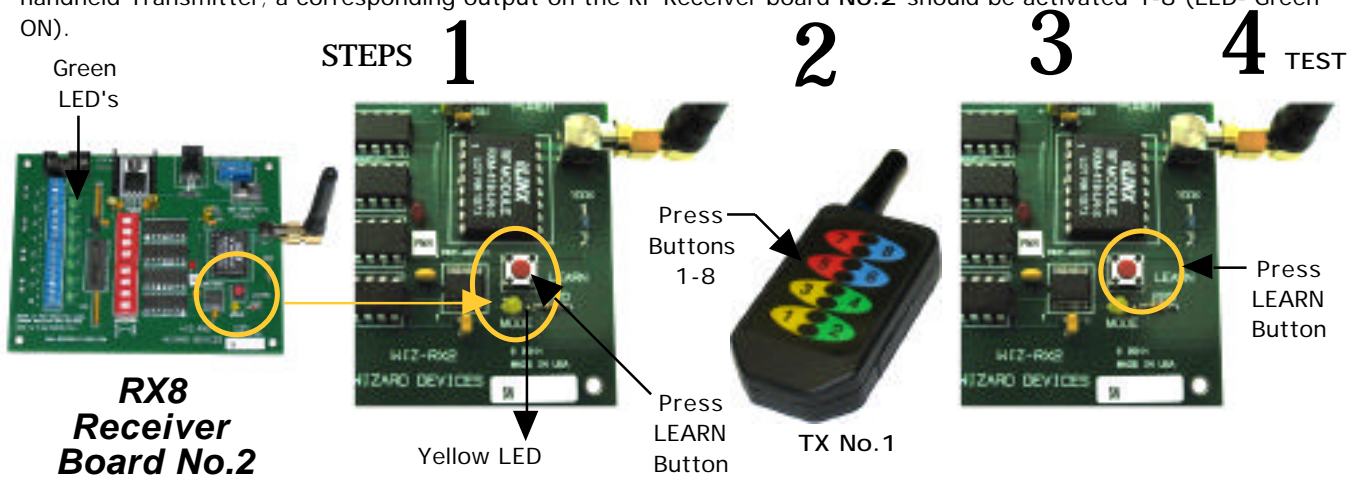

#### Single RF Transmitter and Multiple Receivers

NOTE: Two Receiver boards or more can be activated at the same time and share a common RF handheld Transmitter address. Channels 1-8 on each Receiver board will now be activate together as the single RF Transmitter buttons 1-8 are pressed.

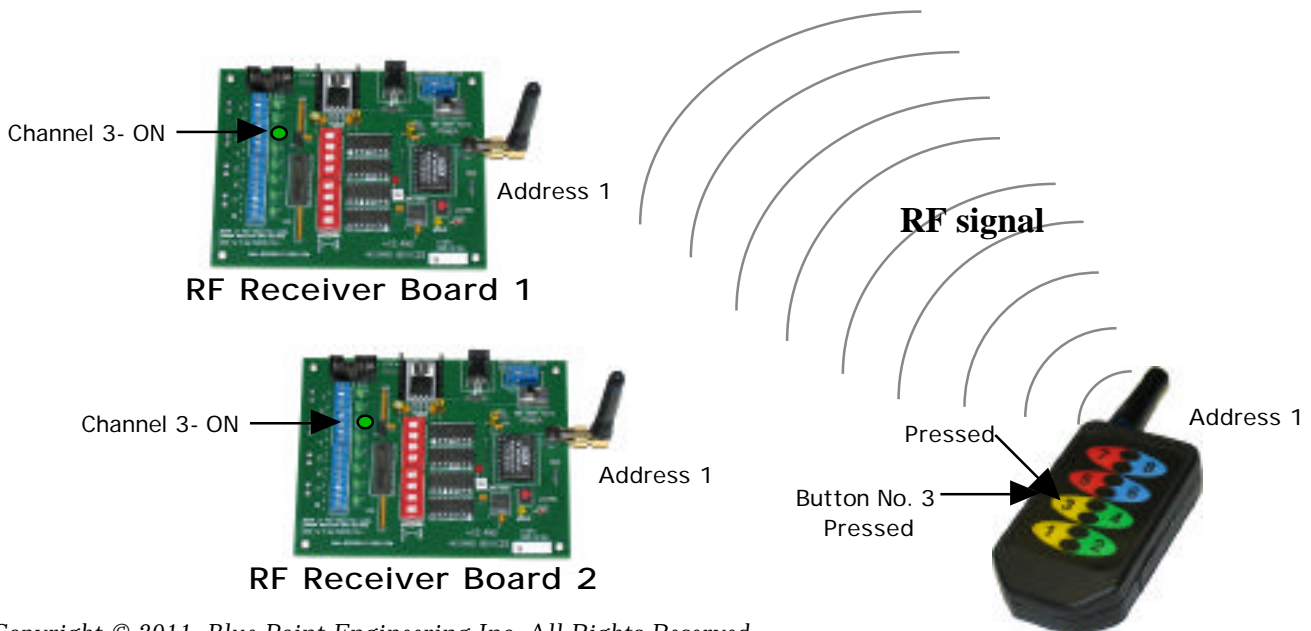

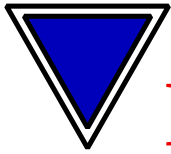

## RX-8 RF System Multiple Receiver Boards

### Set - Up / Applications

#### Single Transmitter with DUO Receiver Board Control

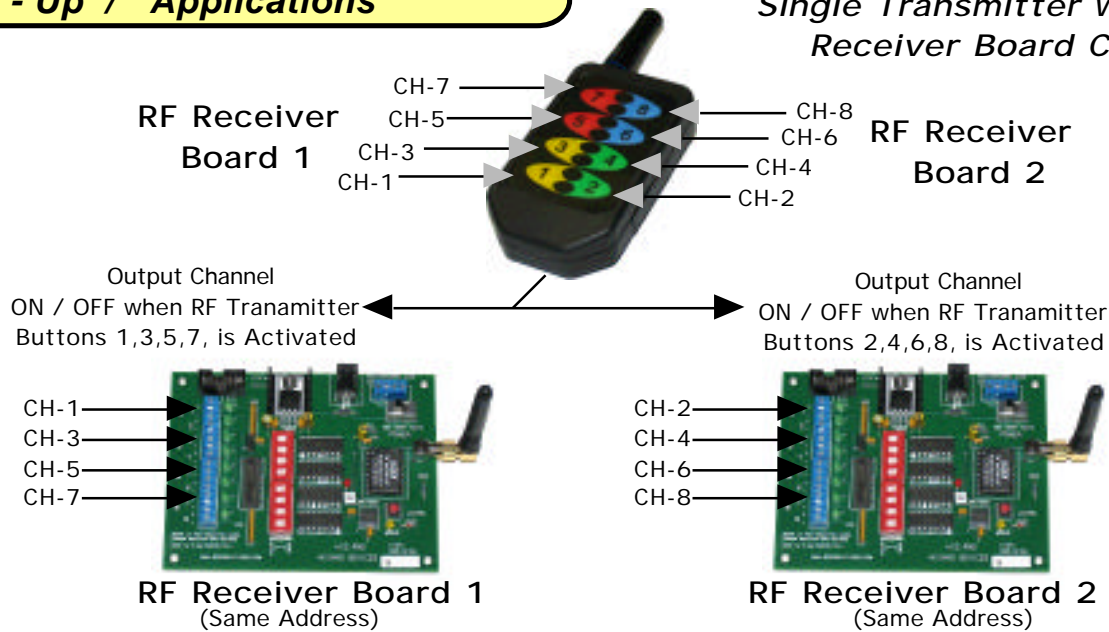

Channels 1,3,5,7 Connected to Device under control  
Channels 2,4,6,8 Not Connected  
*(Note. These channels will turn ON, but nothing is connected to these channels)*

Channels 2,4,6,8 Connected to Device under control  
Channels 1,3,5,7 Not Connected  
*(Note. These channels will turn ON, but nothing is connected to these channels)*

#### Single Transmitter with Mixed Output 3,7,8 Shared

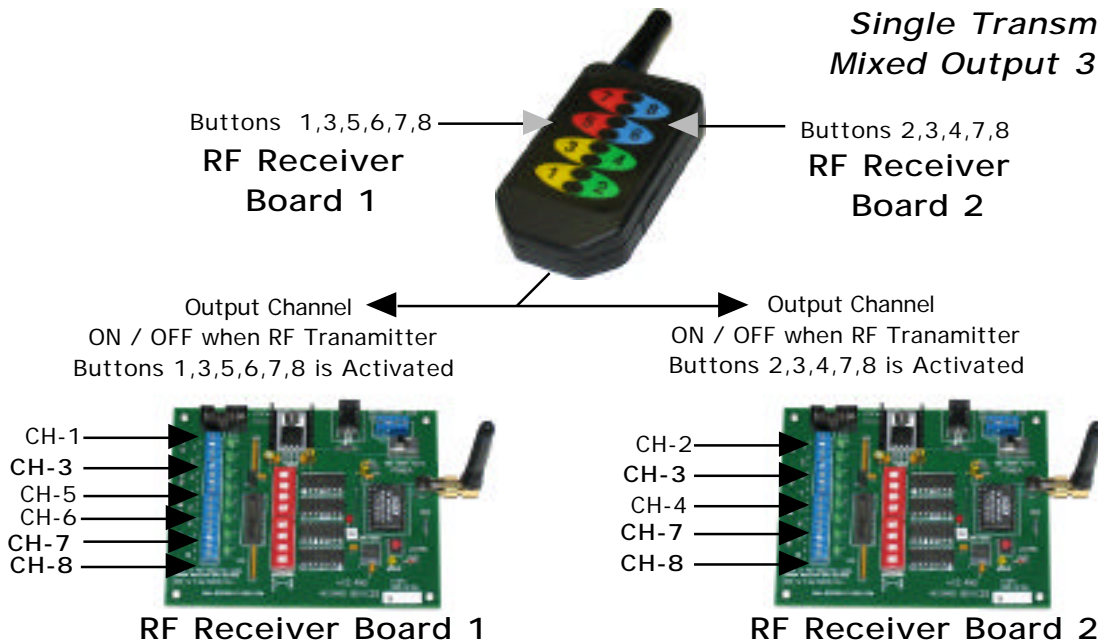

Channels 3,7,8 Activated together on both Receiver Boards No.1 and No.2 when RF Transmitter Button 3,7,8 pressed. Channels 1,5,6 and 2,4 are each independent channels used on Receiver Board No.1 and Receiver Board No.2

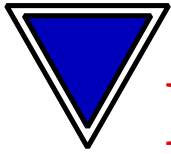

## ***RX-8 RF System RF -Transmitter 418MHz***

### **FCC Compliance, Certification**

#### **INSTRUCTION TO THE USER**

##### **FCC compliance**

This device complies with Part 15 of the FCC Rules.

**Operation of this device is subject to the following two conditions:**

- (1) This device may not cause harmful interference, and
- (2) this device must accept any interference received, including interference that may cause undesired operation.

**This equipment has been tested and found to comply with the limits for a Class B digital device, pursuant to Part 15 of the FCC Rules.** These limits are designed to provide reasonable protection against harmful interference in a residential installation. This equipment generates, uses and can radiate radio frequency energy and, if not installed and used in accordance with the instructions, may cause harmful interference to radio communications. However, there is no guarantee that interference will not occur in a particular installation. If this equipment does cause harmful interference to radio or television reception, which can be determined by turning the equipment off and on, the user is encouraged to try to correct the interference by one or more of the following measures:

Reorient or relocate the receiving antenna.

Increase the separation between the equipment and receiver.

Connect the equipment into an outlet on a circuit different from that to which the receiver is connected.

Consult the dealer or an experienced radio/TV technician for help.

This equipment has been certified to comply with the limits for a Class B computing device, pursuant to FCC Rules. In order to maintain compliance with FCC regulations, shielded cables must be used with this equipment. Operation with non-approved equipment or unshielded cables is likely to result in interference to radio and TV reception. The user is cautioned that changes and modifications made to the equipment without the approval of manufacturer could void the user's authority to operate this equipment.

Long Range Handheld RF Transmitter (8 CH)

FCC ID: OJM-OTX-XXX-LRMSA

IC: 5840-LRMS-XXXX



418MHz

Key Fob Handheld RF Transmitter (5 CH)

FCC ID: OJM-OTX-XXX-KFMSA

IC: 5840A-KFMS-XXXX



418MHz